



Manual

CLDM41A and CLDM42A

Version 3.4



Dear User,

You are advised to carefully read this User Manual before powering on the CLDM41A and CLDM42A Laser distance measuring sensor for the first time.

This is necessary to ensure that you will be able to utilize all the capabilities and features which your new acquisition provides.

This technology is subject to continuously ongoing development.

Editorial deadline: January 2016

Firmware version: ≥ 7.05 and 8.06

Manual version: V 3.4

File: Manual_CLDM41-42A_EN_V3.4.docx

Note:

Proper care has been used in compiling this document. No liability will be accepted in the event of damage resulting from failure to comply with the information contained herein.

Revisions history

Manual Version	Date	Changes
3.4	08.01.2016	Fig. 10 updated, MTBF E19 added
3.3	16.03.2015	New design

ASTECH GmbH, Schonenfaherstr. 5, D-18057 Rostock

Internet www.atech.de E-Mail info@atech.de

Telefon +49 (0)381 / 44073-0 Telefax +49 (0)381 / 44073-20

I. Content

1	General	7
2	Safety Instructions.....	8
2.1	General Safety Instructions	8
2.2	Intended & Conforming Use.....	9
2.3	Nonconforming use	9
2.4	Laser Classification	10
2.5	Electric Supply	10
2.6	Important Operating Advice.....	11
3	Technical Data.....	12
4	Mechanical Mounting Conditions	14
5	Electrical Connection.....	16
5.1	Connector Terminal	16
5.2	Interface Cable.....	16
5.3	Shield and Grounding.....	18
5.4	Termination of RS232	19
6	Limiting Values for Voltages	19
7	Start up	21
8	Commands and Parameter	23
8.1	General	23
8.2	DT – distance tracking	25
8.3	DS – distance tracking (<7 m)	26
8.4	DW – distance tracking with target board (10 Hz)	26
8.5	DX – distance tracking with target board (50 Hz).....	26
8.6	DF – distance measurement with external trigger.....	27
8.7	DM – distance measurement	27
8.8	TP – internal temperature [°C]	27
8.9	SA – display/set average value [1..20]	27
8.10	SD – display/set display format [d/h/s}].....	28
8.11	ST – display/set measure time [0..25]	29

8.12 SF – display/set scale factor	30
8.13 SE – display/set error mode [0/1/2]	31

Content

8.14 AC – display set ALARM center	32
8.15 AH – display/set ALARM hysteresis	33
8.16 AW – display/set ALARM width	33
8.17 HO – display/set Temperature for heating on	33
8.18 HF – display/set Temperature for heating off ¹⁸	34
8.19 RB – display/set distance of I _{OUT} = 4 mA	34 8.20
RE – display/set distance of I _{OUT} = 20 mA	34
8.21 RMx y z – display/set remove measurement	34
8.22 TDx y – display/set trigger delay trigger level	35
8.23 TMx y – display/set trigger mode trigger level	36
8.24 BR – display/set baud rate [2400..38400]	37
8.25 AS – display/set autostart command	37
8.26 OF – display/set distance offset	38
8.27 SO – set current distance to offset	38
8.28 LO – Laser on	38
8.29 LF – laser off	38
8.30 PA – display settings	38
8.31 PR – reset settings	39
9 Interface Connection	40
9.1 Serial Interface RS232	40 9.2
Serial Interface RS422	41
9.3 Output Format on the serial interface	41
9.4 Digital Switching Output (Alarm)	42
9.5 Analog Output	44
9.6 Trigger Input	46
10 List of Commands	47
11 Error Codes	49
12 PC Interface Cable (Option)	50

13	EG Declaration of Conformity	51
14	Part Numbers.....	52

Content II. List of Figures

Figure 1	: Measurement principle	7
Figure 2	: Warning Sign Laser Radiation Class 2	10
Figure 3	: Dimensional drawing	14
Figure 4	: Offset against zero-edge	15
Figure 5	: View of CLDM41A and CLDM42A pole assignments	16
Figure 6	: Interface cable with connector	17
Figure 7	: Interface cable color codes	17
Figure 8	: Isolated Mounting	19
Figure 9	: Recommended terminations wiring for work with open RS-232	20
Figure 10	: Program LDMTTool	22
Figure 11	: Help text Firmware V7.x	24
Figure 12	: Help text Firmware V8.x	25
Figure 13	: Trigger level = 1	37
Figure 14	: Trigger level = 0	37
Figure 15	: Diagram of RS232 wiring at 9-position D-Sub cable jack	40
Figure 16	: Diagram of RS232 wiring at 25-pole D-Sub cable jack	40
Figure 17	: RS232 wiring diagram	41
Figure 18	: Wiring diagram of digital switching output	42
Figure 19	: Digital output behavior with positive and negative hysteresis	43
Figure 20	: Wiring diagram of analog output	44
Figure 21	: Output current diagram for RE > RB and RE < RB	45
Figure 22	: Wiring diagram of trigger input	46
Figure 23	: RS232 cable with power supply for CLDM41A and CLDM42A	50

III. List of Tables

Table 1 : Technical data	12
Table 2 : Pin assignment connector and interface cable	18
Table 3 : Input voltages	21
Table 4 : Output voltages	21
Table 5 : Output format.....	29
Table 6: Examples for Scale factor	32
Table 7 : Meaning of SE	32
Table 8 : List of commands	47
Table 9 : Error Codes	49
Table 10 : Pin assignment SUB-D 9 F	50
Table 11 : Pin assignment CLDM41A and CLDM42A	50
Table 12 : Part Numbers	52

1 General

The CLDM41A and the CLDM42A are Laser sensors to measure distances from 0.1 m to more than 100 m with pinpoint accuracy.

A given target can be clearly identified with the help of a red Laser sighting point. In terms of operating reach, the CLDM41A and the CLDM42A performs depending on the reflectance, morphology and qualities of the target to be measured.

The sensor works based on comparative phase measurement. It emits modulated Laser light which is diffusely reflected back from the target with a certain shift in phase to be compared with a reference signal. From the amount of phase shift, a required distance can then be determined with millimeter accuracy.

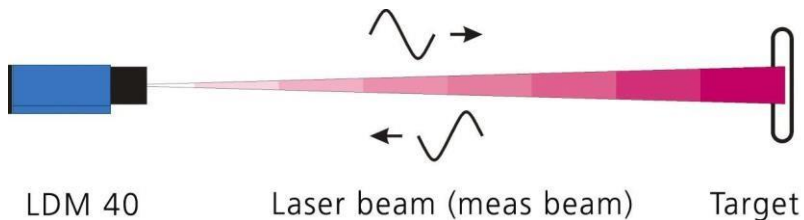

Figure 1 : Measurement principle

A distance measuring cycle can be triggered in three different ways:

- By sending a command from the PC or another equivalent control unit
- By making appropriate prior parameter settings for the auto start command and applying supply voltage
- By external triggering (in remote-trigger mode).

For a more detailed description of these three trigger options, you should consult chapter 8, Commands and Parameter of this User Manual.

Special performance features are:

- Provides high accuracy and great reach under extreme outdoor temperatures.
- Works in a wide range of operating voltages from 10 V= to 30 V= from an on-board vehicle supply point, an industrial direct voltage supply net or a DC power pack.

- Features consistently low power consumption of $<1.5 \text{ W}^1$ (without I_{Alarm})
- Up to 30 m reach for distance measurement, with potential for more than 100 m reach if additional reflectors² are mounted onto the target (depending on reflectance and environmental conditions).
- Visible Laser beam for easier sighting.
- RS232 interface port for input of measuring functions and commands from, and output of measured values to, a PC or a laptop.
- Switching output and analog output are separately programmed.
- Switching output with adjustable limit and hysteresis.
- Measured values can be displayed in meters, decimeters, centimeters, feet and inches due to.
- Option for remote triggering of a measurement from an external trigger device.³

2 Safety Instructions

2.1 General Safety Instructions

These safety and operating instructions should be carefully read and followed during practical work with the CLDM41A and the CLDM42A.



There is danger of Laser radiation or electrical shock. For necessary repair work, the CLDM41A and the CLDM42A may not be opened by anyone other than Manufacturer personnel. Unauthorized intervention into the inner product space will void any warranty claims.

Compliance with all specified operating conditions is necessary.

¹ inactive internal heating for devices with internal heating (CLDM41-42A /h)

² e.g. 3M, self-adhesive foil white non glossy or foil 3290 for longer distances

³ Trigger function is not available for devices with internal heating (CLDM41-42A /h)

Failure to observe advisory notes or nonconforming product usage may cause physical injury to the user or material damage to the CLDM41A and the CLDM42A.

Cable connectors must not be plugged or unplugged under voltage. Remember to turn voltage supply off before you begin working on cable connections.

2.2 Intended & Conforming Use

- Measurement of distances
- Special measuring functions
- Compliance with prescribed temperatures for operation/storage
- Operation at correct voltage level
- Application of specified signal levels to the appropriate data lines

2.3 Nonconforming use

- Do not operate the CLDM41A and the CLDM42A in any other way than described under "Intended & Conforming Use" above and only in a proper working condition
- Safety devices must not be defeated or otherwise rendered ineffective
- Information and warning signs must not be removed

Safety Instructions

- Repair work on the CLDM41A and the CLDM42A must not be carried out by anyone other than authorized personnel.
- Refrain from using the CLDM41A and the CLDM42A without certified protection in an explosive environment
- Measurement with the CLDM41A and the CLDM42A pointed at the sun or other strong light sources may produce faulty results
- Measurement of targets with poor surface reflectance in a strongly reflecting environment may also result faulty measurements.
- Measurement of strongly reflecting surfaces may deliver faulty results.
- Measurement performed through transparent optical media, for example glass, optical filters, Plexiglas, etc. may equally produce incorrect results.

- Measurement on translucent objects (materials allow light to pass through, but are not transparency, e.g. polystyrene, wax, different plastics etc.) can give a too large measured value, since also light is reflected by deeper layers
- Rapidly changing measuring conditions are likely to falsify the result of measurement

2.4 Laser Classification

The CLDM41A and the CLDM42A are Class 2 laser product, ≤ 1 mW as stipulated in EN60825-1:2007, Class 2.

Caution:

There is Class 2 Laser radiation. Do not stare into beam!



Figure 2 : Warning Sign Laser Radiation Class 2

The Laser power is limited to maximum 1 mW. The Laser radiation is visible. A short-term exposure (duration up to 0.25 s) is harmless to the eye.

Users are instructed by Laser warning sign (see Figure 2) to do not stare into the beam. They have to protect themselves by turn the head and/or closing the eyes and by avoid a long look into the beam.

Do not direct the Laser beam onto persons.

The sensor can use without any additional safety protection.

2.5 Electric Supply

Use only 10 V to 30 V DC (direct voltage) for CLDM41A and CLDM42A operation. Use only the specially designated connector terminal for voltage supply.

Specified signal levels must not be exceeded, in order to guarantee correct data communication.

2.6 Important Operating Advice

To make full use of the system's inherent performance capabilities and achieve a long service life, you should always follow these operating rules:

- Do not turn the module on if there is fogging or soiling on its optical parts
- Do not touch any of the module's parts with bare hands.
- Proceed with care when removing dust or contamination from optical surfaces!
- Prevent shock impacts during transport and use of the CLDM41A and CLDM42A
- Prevent overheating of the CLDM41A and CLDM42A.
- Prevent major temperature variances during CLDM41A and CLDM42A operation
- In accordance with IP65 internal protection standards, the CLDM41A and the CLDM42A is designed to be splash proof and dustproof.
- Read these safety and operating instructions with due care and follow them in practical use.

3 Technical Data

Table 1 : Technical Data

Measurement range ⁴	0.1 m up to 30 m with natural surfaces, depending on target reflectance or reflectors more than 100 m achievable ⁵
Measuring accuracy ⁶	<input type="checkbox"/> 2 mm under defined measuring conditions ⁷ <input type="checkbox"/> 3 mm (+15 °C up to +30 °C) <input type="checkbox"/> 4 mm in DS mode <0.5 m (+15 °C ... 30 °C) <input type="checkbox"/> 5 mm (-10 °C up to +50 °C)
Resolution ⁷	0.1 mm, user scalable, standard 1 mm
Reproducibility	<input type="checkbox"/> 0.5 mm
Measuring time	0.24 to 6 s setup or auto Mode DT 0.1 s (10 Hz) mode DW at white surface 20 ms (50 Hz) mode DX at white surface (only CLDM42A)
Target motion speed	≤4 m/s in DX-Mode (CLDM42A only)
Acceleration	≤2,5 m/s ² in DX-Mode (CLDM42A only)
Operating temperature	-10 °C up to +50 °C -40 °C up to +50 °C (only with –h option)
Storage temperature	-40 °C up to +70 °C
Supply voltage	10 V ... 30 V DC (protected against polarity reversal) ⁸
Power consumption	Depending on operation mode < 0.4 W in Standby < 1.5 W for distance tracking < 24 W with heating active (only with –h option)

⁴ dependent on target reflectance, stray light influences and atmospheric conditions

⁵ e.g. 3M, self-adhesive foil white non glossy

⁶ statistic spread 95 % ⁷

for measurement at a planar white target surface in continues movement or still standing, +15 up to +30 °C

⁷ dependent on target reflectance, stray light influences and atmospheric conditions

⁸ Please use only 24V DC For devices with heating (CLDM41A-h and CLDM42A-h) The heater is connected directly to the power supply.

Data interface	RS232 or RS422, baud rate 9600 (2400..38400),
Technical Data	
	ASCII, Format 8N1 (fix)
Digital output	„high-side-switch“, programmable switching threshold and hysteresis, rated for max. load of 0.5 A, HIGH = UB - 2 V, LOW < 2 V
Analog output	4 mA ... 20 mA current output, Adjustable distance range limits, programmable on error event 3 mA oder 21 mA, Load resistance ≤ 500 Ω, Accuracy ± 0,15 %, Temperature drift < 50 ppm/K
Digital input ⁹	External trigger, trigger pulse 3 up to 24 V, pulse length ≥ 1 ms, start of measurement 5 ms + trigger delay, trigger slope and delay can be set (0 ms ... 9999 ms),
EMC	EN 61326-1
Shock resistance	10 g / 6 ms Persistence shock DIN ISO 9022-3-31-01-1
Laser Class	Laser class 2, under EN60825-1:2007, Class 2
Wave length	650 nm (red visible)
Laser divergence ¹⁰¹¹	0.6 mrad
Laser angle tolerance	Better than ± 1° to the ground plane
MTBF	30,000 hours, 24/7, operation temp. +25 °C
Connector	12-pol. M18-male socket, Binder Serie 423
Dimensions (LxWxH)	212 mm x 96 mm x 50 mm
Mounting	100 mm x 85 mm, 4 x M6 holes
Weight	approx. 760 g
Protection class	IP 65 (spatter water and dust protection)

⁹ trigger function is not available for devices with internal heating (CLDM41A-h and CLDM42A-h)

¹⁰ at 10 m distance the beam diameter is 6 mm, at a distance of 50 m it is 3 cm and at a distance of

¹¹ m it is 6 cm

4 Mechanical Mounting Conditions

The casing consists of a rugged, corrosion-resistant extruded aluminum profile with front-side and rear-side covers also in corrosion-resistant design. Four mounting holes are provided in the base plate for mechanical attachment of the CLDM41A and CLDM42A.

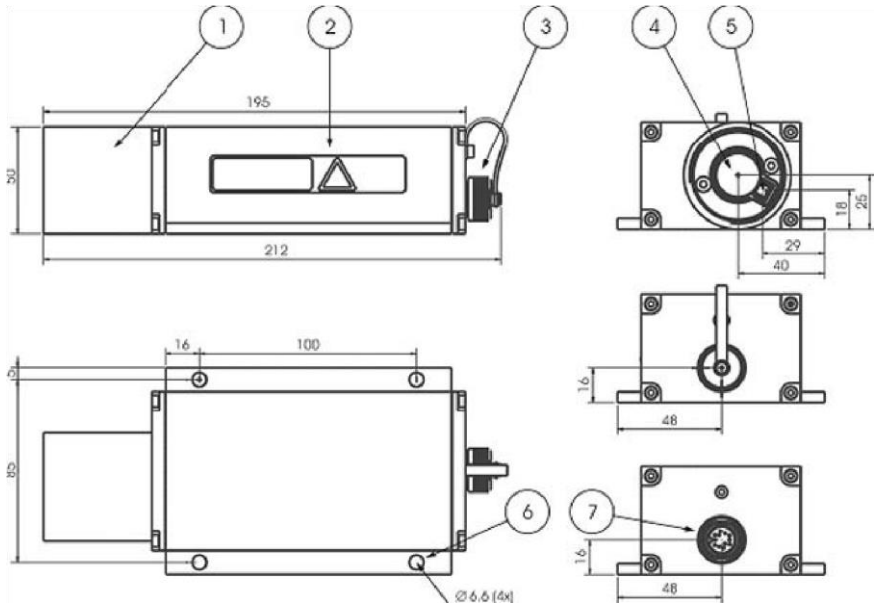

- 1 Equalizer tube at front cover
- 2 Casing
- 3 Protective cap for flange-mount connector
- 4 Receiver optics
- 5 Sender optics
- 6 Mechanical mounting holes (4x)
- 7 12-pole M18-flange-mount connector (Binder Serie 723)

Figure 3 : Dimensional drawing

To protect the sensor's optical surfaces from dust, physical contact, mechanical impacts, etc., the casing has a protection tube attached to it. Optionally different protection windows and optical filters are available.

Please note that measurement cannot be guaranteed to function correctly if the equalizer tube is removed by unqualified action!

The interface connector is located on the back cover. Interface cables with different length are available (standard 2 m, optionally 5 or 10 m).

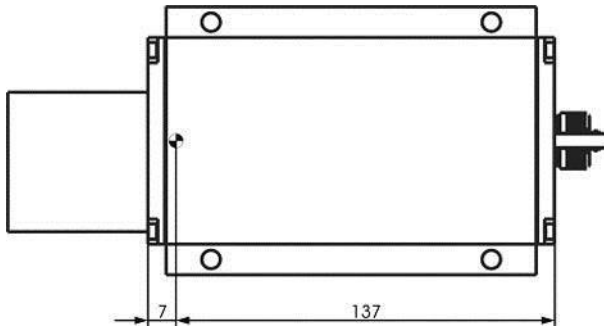

Figure 4 : Offset against zero-edge

The CLDM41A and CLDM42A's zero-point is located 7 mm behind the outer surface of the front cover or 137 mm before the back cover outside face respectively. This zero-point has been introduced for constructional design reasons. It can be compensated with the help of parameter "OF" (see section 8.26 OF – display/set distance offset)

5 Electrical Connection

5.1 Connector Terminal

Located on the back cover is a connector terminal. A 12-pole round-type (flange-mount) series 723 connector from Binder has been selected for this purpose. It is sealed against the casing to comply with IP 65 requirements. This connector type guarantees optimized screening and a high IP degree.

The required counterpart is a cable jack (series 423 from Binder) with grading ring.

Interface cables with different length are available (standard 2 m, optionally 5 or 10 m). Under RS232 C or RS422 norm it's possible to extend the length with a high quality screened cable.

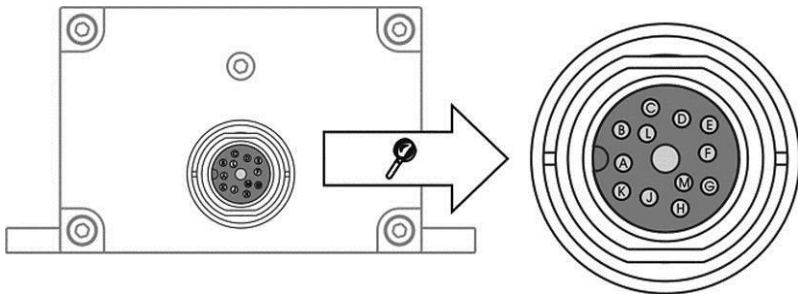

Figure 5 : View of CLDM41A and CLDM42A pole assignments

Electrical Connection

5.2 Interface Cable



Caution: The cable end is exposed! The user is responsible to take precautions that will prevent any kind of shorts! The cable shield has to be connecting to earth with low resistance.



Figure 6 : Interface cable with connector

Interface cable wiring assignments are as follows¹²:

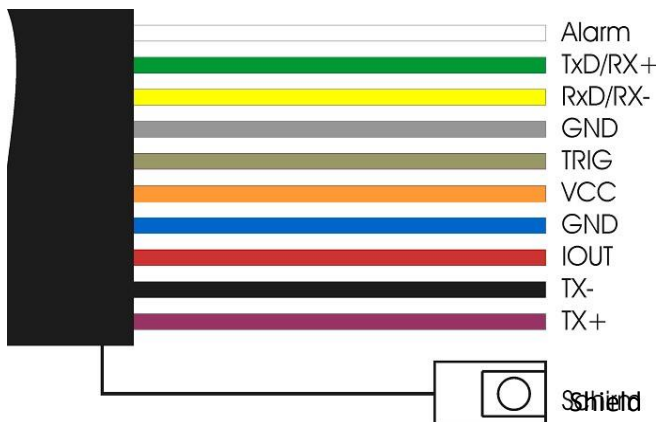

Figure 7 : Interface cable color codes

Table 2 : Pin assignment connector and interface cable

Pin	Color	Assignment	Function RS232	Function RS422
A	Green	TxD / RX+	RS232 send data	RS422 receive data+
B	Yellow	RxD / RX-	RS232 receive data	RS422 receive data-
C ¹³	Brown	TRIG	External trigger input	External trigger input
D	Red	IOU	Analog output	Analog output
E	Black	TX-	RS422 Send data -	RS422 Send data -
F	Violet	TX+	RS422 Send data +	RS422 Send data +
G ¹⁴	Orange/pink	VCC	Supply voltage	Supply voltage
H	White	ALARM	Digital switching output	Digital switching output
J	Grey	GND	Ground potential	Ground potential
L	blue	GND	Ground potential	Ground potential

¹² TRIG is not connected in devices with internal heating (CLDM41A-h and CLDM42A-h)

¹³ Trigger function is not available for devices with internal heating (CLDM41A-h and CLDM42A-h)

¹⁴ The color of pin G, VCC can also be pink.

GND wires are connected to an internal collective ground point. They provide the reference potential for all voltage values quoted below.



Caution: If input signals are applied to an output port, this may damage the CLDM41A and CLDM42A!

Do not connect the current output IOUT (red) to the power supply (10 ... 30 V). This will destroy the interface board!

For data communication via RS232, you are recommended to use cable 4 (grey, GND) for signal ground and cable 7 (blue, GND) for supply ground!

The limiting values of voltages, load rates and logic levels are in accordance with RS232 and RS232 standard requirements.

All outputs are protected against steady short-circuit currents.

5.3 Shield and Grounding

The cable shield must be grounded with low resistance. For cable extension use only high quality shielded cable e.g. type „10XAWG224CULSW“.

Carrier base and control box should be having equal potential. Potential differences are reason for electrical current and can cause EMC problems (no correct measurement function or switch off/on of the gauge necessary).

If no potential equalization is possible, mount the CLDM41A and CLDM42A isolated (3) from the carrier base (use Nylon screwing and washers).

Use screened cable, e.g. “10XAWG224CULSW”, remember to extend also the cable screen (1). Connect screen to power supply reference potential GND on cable end (2).

For integration with vehicles use also this isolated mounting.

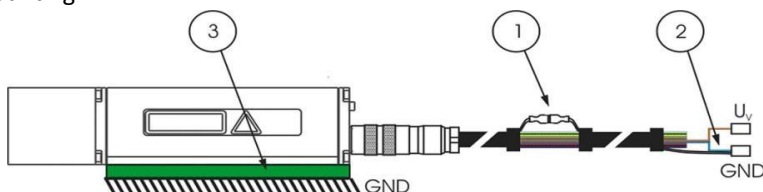
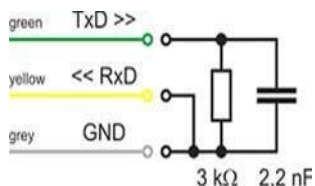

Figure 8 : Isolated Mounting

5.4 Termination of RS232

RxD and TxD data lines should be kept as short as possible in all cases, because they tend to have an interference emitting and interference receiving effect, notably, when in open state. Especially in environments with strong spurious radiation there may be faults that may in some cases require a reset (turning the CLDM41A and CLDM41A off and on again). In cases where no RS232 interface communication is required after parameterization, you should provide for a termination wiring as shown in Figure 9.



Make sure you leave no data line end open. It will be highly sensitive to interferences (EMC).

A terminator circuit should be installed when the RS232 is unconnected. This circuit must be

provided by the customer (see diagram on the

Figure 9 : Recommended terminations wiring for work with open RS-232 left)

Please keep the RS232 norm. The maximal cable length of the RS232 is 15 m. Use alternatively a RS422 connection (shielded twisted pair cable, maximum 300 m, termination resistor 100 Ω).

Limiting Values for Voltages

6 Limiting Values for Voltages

Input voltages:

Table 3 : Input voltages

Terminal point	Voltage	Comment
VCC	30 V	Pole-reversal-protected
TxD	±13.2 V	Short-circuit-proof
RxD	±25 V	Short-circuit-proof

TX+	±14 V	Short-circuit-proof
TX-	±14 V	Short-circuit-proof
RX+	±14 V	Short-circuit-proof
RX-	±14 V	Short-circuit-proof
TRIG ¹⁴	±25 V	Short-circuit-proof

Output voltages:

Table 4 : Output voltages

Terminal point	Voltage	Comment
TxD	±5.4 V	± 5 V at 3 k Ω load
TX+, TX-	\square 2 V	differentially at 2 x 50 \square load
Alarm	\square VCC – 2 V	Level depending on VCC

All outputs are sustained-short-circuit-proof to ground (GND).



Caution: Do not connect the current output IOUT (red) to the power supply (10 ... 30 V). This will destroy the interface board!

¹⁴ Trigger function is not available for devices with internal heating (CLDM41A-h and CLDM42A-h)

7 Start up

Make sure that all cable ends are protected against short circuit effects before you turn on power supply!

Connect cable terminals as required for the particular operating mode. To prevent short circuits, you should seal unused cable ends!

For starting up, a PC with RS232 or RS232 data interface and a terminal program are required. We recommend the Windows program LDMT00L Version 3.0 or higher.

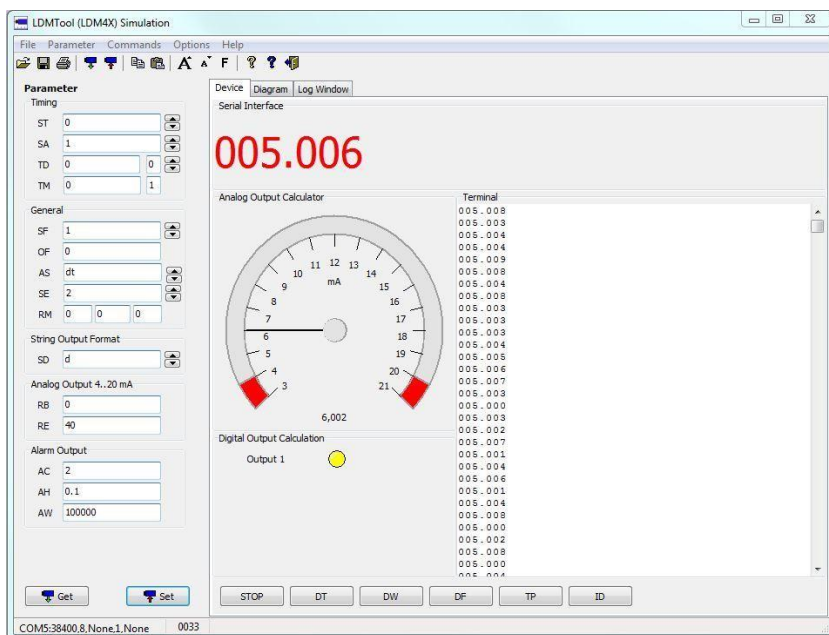

Figure 10 : Program LDMT00L

As part of preparative actions, the CLDM41A and CLDM42A must be properly installed in the designated working site, oriented onto the target and kept in a stable position. The target to be measured should preferentially have a homogeneous, bright surface.

Caution: Do not use any retro reflectors!

Alignment of the CLDM41A and CLDM42A is facilitated by a Laser beam¹⁵ that is visible and can easily be turned on at the PC.

Operating voltage supply must be connected to the corresponding ends of the interface cable. A pole-reversal protection is integrated to prevent the destruction of electronic components.

¹⁵ depending on ambient light and target conditions

8 Commands and Parameter

8.1 General

The CLDM41A and CLDM42A can be parameterized very easy with the PC. The PC must be equipped with a serial interface RS232 and/or RS422 according to the attached CLDM41A and CLDM42A. The use of USB to serially converters is also possible. An optionally programming cable is necessary (see chapter 12, PC Interface Cable (Option)). On the PC a terminal program must be installed (LDMTOOL or HyperTerminal). By selecting ID[Enter] command, you may call up the menu with available setup commands (DX[Enter] only CLDM42A):

```
CLDM4x, s/n xxxxxx, v 7.x
DT[Enter].....distancetracking
DS[Enter].....distancetracking 7m
DW[Enter].....distancetracking with cooperative target(10Hz)
DX[Enter].....distancetracking with cooperative target(50Hz)
DF[Enter].....distance measurement with external trigger
DM[Enter].....distance measurement
TP[Enter].....internal temperature [C]
SA[Enter] / SAx[Enter].....display/set average value [1..20]
SD[Enter] / SDd[Enter].....display/set display format [d/h/s]
ST[Enter] / STx[Enter].....display/set measure time [0..25]
SF[Enter] / SFx.x[Enter].....display/set scale factor SE[Enter] /
SEx[Enter].....display/set error mode [0/1/2]
                                0..Iout=const., ALARM=const.
                                1..Iout: 3mA @RE>RB, 21mA @RE<RB,
                                ALARM: OFF@AH>0, ON@AH<0
                                2..Iout: 21mA @RE>RB, 3mA @RE<RB,
                                ALARM: ON@AH>0, OFF@AH<0
AC[Enter] / ACx.x[Enter].....display/set ALARM center
AH[Enter] / AHx.x[Enter].....display/set ALARM hysteresis
AW[Enter] / AWx.x[Enter].....display/set ALARM width
RB[Enter] / RBx.x[Enter].....display/set distance of Iout=4mA RE[Enter] /
REx.x[Enter].....display/set distance of Iout=20mA
RM[Enter] / RMx y.y z[Enter]..remove measurement
TD[Enter] / TDx y[Enter].....display/set trigger delay [0..9999ms]
trigger level [0/1]
TM[Enter] / TMx y[Enter].....display/set trigger mode [0/1] trigger
level [0/1]
BR[Enter] / BRx[Enter].....display/set baud rate [2400..38400]
AS[Enter] / ASd[Enter].....display/set autostart command [DT/DS/
                                DW/DX/DF/DM/TP/LO/ID]
OF[Enter] / OFx.x[Enter].....display/set distance offset
SO[Enter].....set current distance to offset
                                (offset = - distance)
LO[Enter].....laser on
LF[Enter].....laser off
PA[Enter].....display settings
PR[Enter].....reset settings
```

Figure 11 : Help text Firmware V7.x

```

CLDM42, SN xxxxx, V 8.02
DT[Enter].....distance tracking
DS[Enter].....distance tracking 7m
DW[Enter].....distance tracking with cooperative target
                    (10Hz)
DX[Enter].....distance tracking with cooperative target
                    (50Hz)
DM[Enter].....distance measurement
TP[Enter].....internal temperature [C]
SA[Enter] / SAx[Enter].....display/set average value [1..20]
SD[Enter] / SDd[Enter].....display/set display format [d/h/s]
ST[Enter] / STx[Enter].....display/set measure time [0..25]
SF[Enter] / SFx.x[Enter].....display/set scale factor SE[Enter] /
SEx[Enter].....display/set error mode [0/1/2]
                    0..Iout=const., ALARM=const.
                    1..Iout: 3mA @RE>RB, 21mA @RE<RB, ALARM:
                    OFF@AH>0, ON@AH<0
                    2..Iout: 21mA @RE>RB, 3mA @RE<RB, ALARM:
                    ON@AH>0, OFF@AH<0
AC[Enter] / ACx.x[Enter].....display/set ALARM center
AH[Enter] / AHx.x[Enter].....display/set ALARM hysteresis
AW[Enter] / AWx.x[Enter].....display/set ALARM width
HO[Enter] / HOx[Enter].....display/set temperature of heating on [ -40*C
... +70*C]
HF[Enter] / HFx[Enter].....display/set temperature of heating off[ -40*C
... +70*C]
RB[Enter] / RBx.x[Enter].....display/set distance of Iout=4mA RE[Enter] /
REx.x[Enter].....display/set distance of Iout=20mA
RM[Enter] / RMx y.y z[Enter]..remove measurement
BR[Enter] / BRx[Enter].....display/set baud rate [2400..38400]
AS[Enter] / ASd[Enter].....display/set autostart command
                    [DT/DS/DW/DX/DM/TP/LO/ID]
OF[Enter] / OFx.x[Enter].....display/set distance offset
SO[Enter].....set current distance to offset
                    (offset = -distance)
LO[Enter].....laser on
LF[Enter].....laser off
PA[Enter].....display settings
PR[Enter].....reset settings

```

Figure 12 : Help text Firmware V8.x

In preparation of a measurement so the sensor can be adapted by intelligent parameterize optimally to the measuring conditions and the measuring task.

All valid settings will be preserved on turning the CLDM41A and CLDM42A off! They can only be replaced with new value entries or changed back to their standard values by running an initialization routine.

Command entries are not case-sensitive. This means that small and capital lettering can be used for commands.

Any command must be terminated by a hexadecimal 0Dh (carriage return) character.

Where decimal digits are to be entered, they must be separated by period (2Eh).

For command parameter entries, one must distinguish between parameter settings and parameter queries.

Querying is achieved with a command in simple format, e.g. (for alarm center parameters):

```
AC[Enter]
```

For parameter setting, a new value must be added after the command with no delimitation sign in between, for example:

```
AC20.8[Enter]
```

In the given example, the alarm center will be set to 20.8.

8.2 DT – distance tracking

Input parameter SA, SD, SE, SF, ST, OF

Output RS232/RS422, digital switching output, analog output

DT mode can be chosen for distance measurement of different kinds of surfaces (varying reflectance). In this type of distance tracking mode, the CLDM41A and CLDM42A uses internal algorithms to continuously evaluate the quality of the Laser radiation signal that is coming back. This may cause longer measuring times in the case of poor reflectance or sudden jumps in distance.

The minimum time to measure is 240 ms, the maximum time is 6 s. If the measuring signal fails to reach a specified quality within six seconds, an error message is output.

The time to measure may also be limited by setting the ST parameter to a desired value. ESC stops the measurement.

8.3 DS – distance tracking (<7 m)

Input parameter SA, SD, SE, SF, ST, OF

Output RS232/RS422, digital switching output, analog output

Operation in DS mode makes sense where different types of surfaces have to be measured at close range up to 7 m. Compared to DT measuring mode, it allows a higher measurement rate. Within the range from 0.1 m to 0.5 m, measuring accuracy is restricted (± 4 mm). Measuring time (time to measure) can be limited via ST parameter settings.

ESC stops the measurement.

8.4 DW – distance tracking with target board (10 Hz)

Input parameter SA, SD, SE, SF, OF

Output RS232/RS422, digital switching output, analog output

DW mode performs at a steady measuring rate of 10 Hz. As a necessary precondition for measured values to be stable, a white target board must be placed at the selected object. There must be no sudden jumps in distance greater than 16 cm within the measuring field! ESC stops the measurement.

8.5 DX – distance tracking with target board (50 Hz)

Input parameter SA, SD, SE, SF, OF

Output RS232/RS422, digital switching output, analog output

DX mode performs at a steady measuring rate of 50 Hz (only CLDM42A). As a necessary precondition for measured values to be stable, a white target board must be placed at the selected object.

This measurement mode is intended in the first place for objects performing homogeneous motion up to 4m/s. For higher rates of measurement, preceding measured values will be included in the process to calculate a currently measured value. There must be no sudden jumps in distance greater than 16 cm within the measuring field!



Caution: To prevent transmission problems, please use 9600 baud as the minimal baud rate for DX Mode!

8.6 DF – distance measurement with external trigger¹⁶

Input parameter SD, SE, SF, ST, OF, TD, ST, SA, RM
 Output RS232/RS232, digital switching output, analog output

DF mode allows a measurement that is triggered by an external trigger pulse.

Initially, after selecting this mode, the operator does not receive any response. As soon as the trigger pulse has been detected, the CLDM41A and CLDM42A will send data and switches to digital and/or analog output.

Settings for trigger delay (delay) and trigger slope can be defined via parameter TD (see 8.22 TDx – display/set trigger delay trigger level).

With ST=1 the maximum trigger frequency should not exceed 3.5 Hz.

8.7 DM – distance measurement

Input parameter SD, SE, SF, ST, OF
 Output RS232/RS232, digital switching output, analog output

DM mode triggers a single measurement (single shot)

8.8 TP – internal temperature [°C]

TP queries the value of the inner CLDM41A and CLDM42A temperature.

Note: In tracking mode, the inner temperature may exceed the surrounding temperature level by as much as 10 K.

8.9 SA – display/set average value [1..20]

SA allows you to calculate a floating average value from 1 to 20 measured values. Calculation is based on this formula:

$$\text{Average value: } \bar{x} = \frac{x_1 + x_2 + x_3 + \dots + x_{n(20)}}{n}$$

Standard setting is 1 (no average).

¹⁶ Trigger function is not available for devices with internal heating (CLDM41A-h and CLDM42A-h)

8.10 SD – display/set display format [d/h/s]]

SD selects the output format of measured value data. There are three modes available:

Table 5 : Output format

Parameter	Output	Format
d	decimal	xxx.xxx<CR><LF> x=0...9
h	hexadecimal	<SPACE>xxxxxx<CR><LF> x=0...F
s	decimal with signal quality	xxx.xxx<SPACE>yyyyyy<CR><LF> x=0...9; y=0...9

SD affects all commands that output a distance value.

An output value is calculated from a given measured distance value (in mm), multiplied by the scale factor SF.

Negative distance values are output in two's complement notation.

The value for the signal quality varies between 0 and 1024. 0 means a bad signal quality while 1024 indicates a very good signal quality.

Examples:

Distance = 4,996 m, SF1

dec: 004.996<CR><LF>

hex: <SPACE>001384<CR><LF>

(= 4996 mm × SF1)

dec+sig: 004.996_000005<CR><LF>

(bad signal quality)

dec+sig: 004.996_000985<CR><LF>

(good signal quality)

Distance = 4,996 m, SF10

dec: 049.960<CR><LF> hex:

_00C328<CR><LF> (= 49960

= 4996 mm × SF10) dec+sig:

049.960_000005<CR><LF>

Error case dec/hex:

E15<CR><LF>

(see 11 Error Codes)

8.11 ST – display/set measure time [0..25]

Measuring time is directly conditional on the selected measuring mode. As a general rule, one may say: the poorer the reflectance of the surface of a particular target, the more time the CLDM41A and CLDM42A will require to determine the distance with specified accuracy. For example, if error message E15 is output because of poor reflectance and insufficient time to measure, this latter setting must be increased.

The available value range for measuring time is 0 to 25. Basically, the greater the time setting is the more time will be available for measurement and the lower the resulting measuring rate.

An exception there from is zero-value. In this case, the CLDM41A and CLDM42A automatically picks the smallest possible time value for measurement!

The CLDM41A and CLDM42A comes factory-set with $ST = 0$.

ST is effective in the DT, DF and DM mode of operation.

The measuring time setting option can also be used to modify the measuring rate, for example, in order to restrict the data volume or for synchronization purposes. Measuring time can only be set as an approximate value, because the underlying principle of measurement is subject to certain variances that cannot be accounted for:

DT measuring mode \rightarrow measuring time = $ST \times 240$ ms (except $ST = 0$) DS

measuring mode \rightarrow measuring time = $ST \times 150$ ms (except $ST = 0$)

Example:

The target distance is 25 m, but the target's reflectance is not ideal. With a measuring time setting of ST 2, E15 will be output following measurement. The user must increase the time ($ST > 2$) or set auto ($ST 0$) to measure in this case!



One should work in DW or DX measuring mode where stable measuring times are required.

8.12 SF – display/set scale factor

SF multiplies a calculated distance value with a user-selectable factor for changes in resolution or outputs in a different unit of measure. The scale factor may also be negative. Standard setting is 1.

The scale factor influence the output of measurement results, Offset (OF), Alarm Centre (AC), Alarm Hysteresis (AH), Range Begin (RB) and Range End (RE)!

Table 6: Examples for Scale factor

Scale factor	Resolution	Output	Output Unit
--------------	------------	--------	-------------

SF1	1 mm	012.345	m
SF10	0.1 mm	123.450	dm
SF1.0936	0.01 yard	013.500	yard
SF3.28084	0.01 feet	040.501	feet
SF0.3937	1 inch	004.860	100 inch
SF-1	1 mm	-12.345	m



Note: Following a change in the scale factor, the settings for digital and/or analog output and offset must be matched accordingly!

8.13 SE – display/set error mode [0/1/2]

SE (error mode) allows you to configure the behavior of the digital switching output (alarm) and/or the analog output following an error message (E15, E16, E17). Depending on the particular CLDM41A and CLDM42A application environment, error messages have to be handled in different ways.

Available setting options are 0, 1 and 2 with the following effects in the case of an error:

Table 7 : Meaning of SE

SE	Digital switching output (Alarm)	Analog output (4 -20 mA)
0	ALARM of latest valid measurement	Outputs current of last valid measurement
1	Positive alarm hysteresis = LOW Negative alarm hysteresis = HIGH	RE >RB: Current =3 mA RE <RB: Current =21 mA
2	Positive alarm hysteresis = HIGH Negative alarm hysteresis = LOW	RE >RB: Current =21 mA RE <RB: Current =3 mA

8.14 AC – display set ALARM center

AC sets the beginning of the distance range, for which the switching output will be turned active. The length of this active range can be set using the AW parameter.

AC must be selected in keeping with the currently set SF scale factor (see 9.4 Digital Switching Output (Alarm)).

8.15 AH – display/set ALARM hysteresis

AH allows you to make parameter settings for the switching hysteresis at the beginning and the end point of the active range of the switching output.

AH must be selected so it is properly matched to the currently valid scale factor (SF).

The mathematical sign of AH can be used to set an active state logic level:

Positive sign (“+”): active range is HIGH-active.

Negative sign (“-“): active range is LOW-active.

No sign setting means positively-signed (see 9.4 Digital Switching Output (Alarm)).

8.16 AW – display/set ALARM width

AW sets the length of the active range, beginning at AC.

AW settings must be made in agreement with the currently valid SF scale factor.

AW is always equal or greater than “0” (zero).

AW is always equal or greater than |AH| (the amount of AH).

Standard setting is 100000 – means off.

8.17 HO – display/set Temperature for heating on¹⁷

HO displays/sets the temperature value at which the internal heating is switched on. The values can be varied between -40°C and 70°C.

Standard setting is 3°C.

8.18 HF – display/set Temperature for heating off¹⁸

HF displays/sets the temperature value at which the internal heating is switched off. The values can be varied between -40°C and 70°C. Standard setting is 12°C.

¹⁷ Only for devices with internal heating (CLDM41A-h and CLDM42A-h)

8.19 RB – display/set distance of $I_{OUT} = 4 \text{ mA}$

RB (Range Begin) defines the point of a distance range at which the analog output will begin to deliver varying distance readings.

At a distance of RB, the output current will be 4 mA.

RB must be selected so it is properly matched to the currently valid scale factor (SF) setting.

RB can be smaller or greater than RE! (see 9.5 Analog Output) In the event of a fault, the output value will correspond to the current that was set via parameter SE.

8.20 RE – display/set distance of $I_{OUT} = 20 \text{ mA}$

RE (Range End) defines the point of a distance range at which the analog output will cease to deliver varying distance readings. At a distance of RE, a current of 20 mA will be output.

RE must be selected so it is properly matched to the currently valid scale factor (SF) value. RE can be greater or smaller than RB!

In the event of a fault, the output value will correspond to the current that was set via parameter SE.

8.21 RMx y z – display/set remove measurement

Standard setting: 0 0 0

RM is intended to facilitate settings for a range of expected distance values.

Values which are found to be outside of this expected range will be corrected until matching the most recently valid measured values.

RM is only effective in DT mode.

It consists of three parameters which are separated by space (20h).

x designates the number of preceding measured values that will be evaluated in the case of non-conforming measurement. A maximum of ten preceding measured values can be evaluated.

- y defines the range of permissible values. If this range is exceeded in negative or positive direction, the respective measured value will be corrected accordingly.
- z stands for the number of values that are out of the permissible value range (out of tolerance values). In the event of out-of-tolerance values arriving in succession, the most recently corrected value will be included in the correction process for the next out-of-tolerance value. The maximum allowed number of out-of-tolerance values is 100.



Important: The use of RM parameter settings should be restricted to suitable applications only. Improper use of the parameter may create safety hazards!

8.22 TDx y – display/set trigger delay trigger level¹⁸

TD is only intended for the configuration of the remote trigger input (see 8.6 DF – distance measurement with external trigger).

TD consists of two sub parameters, of the actual delay value, i.e. the delay time, and the trigger level.

Trigger delay corresponds to the time from arrival of the trigger signal to the starting point of a measurement. It may be set to any value between 0 and 9999 ms. With the help of the trigger level one may define if measurement is to begin on a rising or a falling pulse slope.

Trigger delay and trigger level must be separated by space (20h) in the entry line. Standard setting: 0 0.

- x Delay time between trigger signal and start of measurement, delay can be set from 0 to 9999 ms.
- y 0 for HIGH → LOW-slope 1 for LOW → HIGH-slope

Example:

```
TD1000_0[Enter]
```

¹⁸ Trigger function is not available for devices with internal heating (CLDM41A-h and CLDM42A-h)

In the given example, the delay has been set to 1000 ms and the trigger slope to "rising" (LOW-to-HIGH transition)

8.23 TMx y – display/set trigger mode trigger level¹⁹

TM provides parameter setting options for the auto-start trigger function which allows external triggering of the auto-start command that was set via parameter AS. Triggering is accomplished via the external trigger input. All starting modes which are selectable via AS can be launched and stopped by external triggering. These are: DS/DT/DW/DX/DF/DM/TP/LO/ID.

TM consists of two parameters which are separated by space (20h).

x 0... Trigger function turned off 1... Trigger function turned on

y 0 ... measurement is triggered on trigger line at L-level
(HIGH → LOW slope)

1 ... measurement is triggered on trigger line at H-level
(LOW → HIGH slope)

Standard setting is TM0 1.

For triggering, the trigger level must be permanently applied!

Examples:

- a) ASDT
 TM1 1
 Trigger signal = H → DT is performed
 Trigger signal = L → DT is stopped

Commands and Parameter

¹⁹ Trigger function is not available for devices with internal heating (CLDM41A-h and CLDM42A-h)

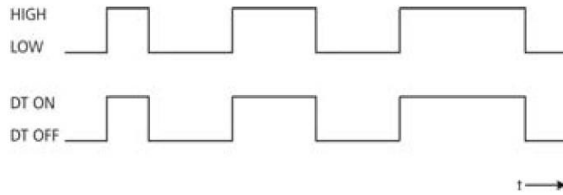

Figure 13 : Trigger level = 1

b) ASDM

TM1 0

Trigger signal=H → no change in state

Trigger signal=L → DM active, i.e. one measurement is triggered

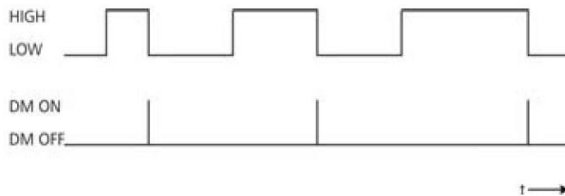

Figure 14 : Trigger level = 0

8.24 BR – display/set baud rate [2400..38400]

Available baud rate settings are: 2400, 4800, 9600, 19200, 38400. Faulty entries will be rounded to the nearest baud rate. A fixed data format of eight data bits, with no parity and one stop bit is used. Standard setting is 9600 baud.

8.25 AS – display/set autostart command

AS (auto start) defines which function will be carried out when power becomes available to the CLDM41A and CLDM42A.

Possible entries are those delivering a measured value on the output side, an ID command or the command for turning the Laser on (LO).

For example, if ASDT has been parameterized, the CLDM41A and CLDM42A will begin with distance tracking on turning on power.

8.26 OF – display/set distance offset

With the help of OF (offset) the user may define a zero-point for his/her application. For details on the position of the module's zero-point, refer to section 4.

OF must be selected so it is properly matched to the currently valid scale factor setting (SF).

OF may also take on negative values. Standard setting: 0

8.27 SO – set current distance to offset

SO performs a distance measurement and saves the measured reading as an offset value with inverted mathematical sign (OF).

8.28 LO – Laser on

LO turns the Laser on. This function can be used for orientation or functional testing of the CLDM41A and CLDM42A. After the command LO it's necessary to send LF! Don't use LO because this. Please use instead of LO the command DT to turn the Laser on.

8.29 LF – laser off

LF turns the Laser off.

8.30 PA – display settings

PA lists all parameters in a table.

Commands and Parameter

8.31 PR – reset settings

PR resets all parameters (except baud rate). After this a new configuration of the CLDM41A and CLDM42A is necessary

```
average value[SA].....1 display
format[SD].....d measure
time[ST].....0 scale
factor[SF].....1 error
```

```
mode[SE].....1 ALARM
center[AC].....1000
ALARM hysteresis[AH].....0.1 ALARM
width[AW].....100000 distance
of Iout=4mA [RB].....1000 distance of
Iout=20mA [RE].....2000 remove
measurement [RM].....0 0 0 trigger
delay, trigger level[TD]..0 0 trigger mode,
trigger level[TM]...0 1 baud
rate[BR]......9600 autostart
command[AS].....ID distance
offset[OF].....0
```



Use instead of PR the "Set Standard" command from Windows program LDMTTool.

9 Interface Connection



The CLDM41A and CLDM42A provide one serial port type **RS232** or **RS232** depending on the version (see label). For devices with RS232, the RS232 transmission lines (TX +, TX-) are also available.

9.1 Serial Interface RS232

Initially, RS232 communication interfaces purely functioned as PC communication ports. They have become the established standard tool for serial data transmission over short cable lengths. With greater transmission lengths, the interface is highly susceptible to interferences, notably, in the vicinity of strong electromagnetic noise emitters.

Therefore, it should only be used for CLDM41A and CLDM42A configuration.

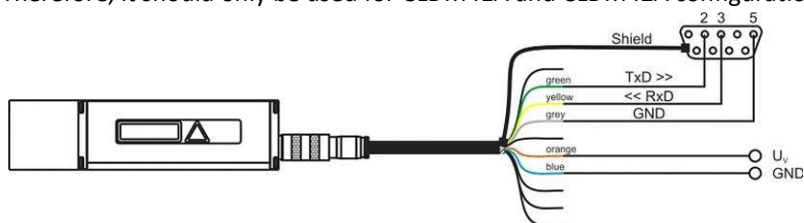

Figure 15 : Diagram of RS232 wiring at 9-position D-Sub cable jack

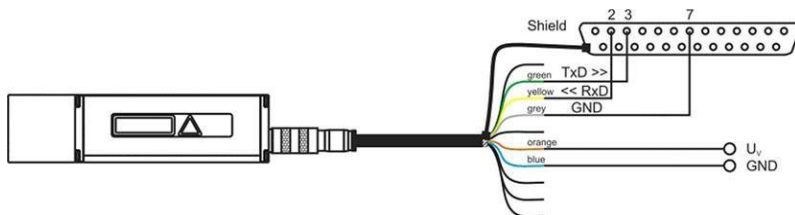

Figure 16 : Diagram of RS232 wiring at 25-pole D-Sub cable jack

The commands of the serial interface are described in chapter 8 starting page 24. The data output format is determined by parameter SD (display format), see page 29.

9.2 Serial Interface RS422

For configuration purposes and permanent data transmissions over a greater length, the RS422 can be used. This type of interface is insusceptible to interference and noise influences and qualifies for industrial use. Where twisted cable pairs are involved, transmissions lengths up to 300 m can be handled.

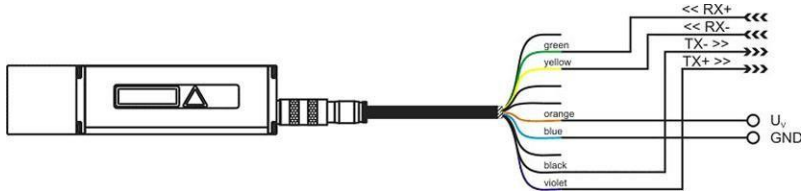

Figure 17 : RS232 wiring diagram

Since a standard PC typically includes no RS422 communication port, you require an RS422 interface card or an RS422-to-RS232 converter for communication.

9.3 Output Format on the serial interface

The output format on the serial interface is selected by the command SD. There are three modes available:

Parameter	Output	Format
d	decimal	xxx.xxx<CR><LF> x=0...9
h	hexadecimal	<SPACE>xxxxxx<CR><LF> x=0...F
s	Decimal with signal quality	xxx.xxx<SPACE>yyyyyy<CR><LF> x=0...9; y=0...9

SD affects all commands that output a distance value.

An output value is calculated from a given measured distance value (in mm), multiplied by the scale factor SF.

Negative distance values are output in two's complement notation.

The value for the signal quality varies between 0 and 1024. 0 means a bad signal quality while 1024 indicates a very good signal quality.

Examples:

Distance = 4,996 m, SF1

```

dec: 004.996<CR><LF> hex:
    <SPACE>001384<CR><LF>
    (= 4996 mm × SF1) dec+sig:
    004.996_000005<CR><LF>
    (bad signal quality) dec+sig:
    004.996_000985<CR><LF>
    (good signal quality)
  
```

Distance = 4,996 m, SF10

```

dec: 049.960<CR><LF> hex:
    _00C328<CR><LF>
    (= 49960 = 4996 mm × SF10) dec+sig:
    049.960_000005<CR><LF>
  
```

```

Error case dec/hex:
    E15<CR><LF>
  
```

(see page 49, chapter 11, Error Codes)

9.4 Digital Switching Output (Alarm)

With the help of a user-selectable distance threshold, the switching output can be set to monitor objects or conditions for positive or negative overstep.

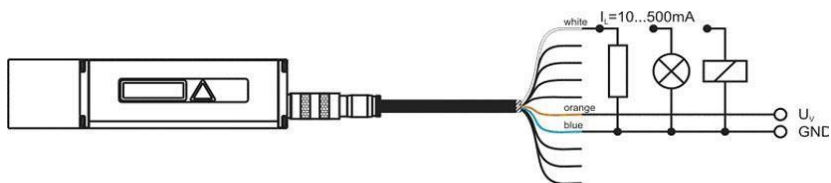

Figure 18 : Wiring diagram of digital switching output

For example, using the digital switching output, an object which was selected for measurement can be monitored for excision of a threshold value. To do this, parameter settings for a measurement window are required. Settings for this window can be made via the three parameters: Alarm Center (AC), Alarm Hysteresis (AH) and Alarm Width. The range which will be subject to monitoring begins at AC and ends at AC+AW. Switching transitions can be set via parameter AH.

The logic state of the switching output follows from the mathematical sign of AH.

In the case of a positive AH, the output switches

- with increasing distance:

- from LOW to HIGH if the distance is greater than $(AC \pm AH/2)$
- from HIGH to LOW if the distance is greater than $(AC+AW+AH/2)$ -

with decreasing distance:

- from LOW to HIGH if the distance is smaller than $(AC + AW - AH/2)$
- from HIGH to LOW the distance is smaller than $(AC - AH/2)$

In the case of a negative AH, the output switching pattern will be inverse.

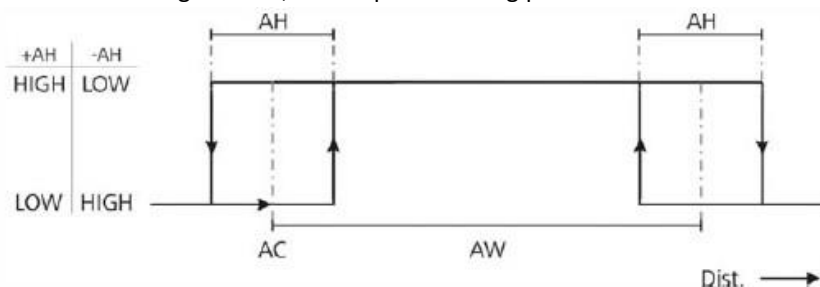

Figure 19 : Digital switching output behavior with positive and negative hysteresis

Example:

A moving object is assumed to be monitored within a window of 10 m to 11 m with a hysteresis of 0.2 m.

AC10
AH0.2
AW1

Distance (m) increases →										
	9.8	9.9	10.0	10.1	10.2	...	11.0	11.1	11.2	11.3
+AH	L	L	L	H	H	H	H	L	L	L
-AH	H	H	H	L	L	L	L	H	H	H

Distance (m) decreases →										
	11,3	11,2	11,1	11,0	10,9	10,8	...	10,0	9,9	9,8
+AH	L	L	L	L	H	H	H	H	H	L
-AH	H	H	H	H	L	L	L	L	L	H

L = LOW, H = HIGH

How the switching output is to behave on occurrence of an error message (E15, E16, E17, E18) can be defined by making suitable settings under “SE” (see 8.13, SE – display/set error mode [0/1/2])

9.5 Analog Output

The purpose of the analog output is to allow transmission of analog measured values via a 4..20mA interface.



Figure 20 : Wiring diagram of analog output

The current is proportional to the measured target distance. This applies within a distance interval that is marked by the two limiting parameters “Range Begin” (RB) and “Range End” (RE), where RE may be greater or smaller than RB (see 8.17 and 8.20)

The output current value is calculated according to this equation:

$$RE > RB: \quad I_{OUT} [mA] = 4 \text{ mA} + 16 \cdot \left(\frac{\text{Distanz} - RB}{RE - RB} \right) \cdot \text{mA}$$

$$RE < RB: \quad I_{OUT} [mA] = 20 \text{ mA} - 16 \cdot \left(\frac{\text{Distanz} - RE}{RB - RE} \right) \cdot \text{mA}$$

Current out of distance range:

	Distance = RB	Distance = RE
RE > RB	4 mA	20 mA
RB > RE	20 mA	4 mA

Example:

RB	RE	0 m	2 m	4 m	6 m	8 m	10 m	11 m
2 m	10 m	4 mA	4 mA	8 mA	12 mA	16 mA	20 mA	20 mA

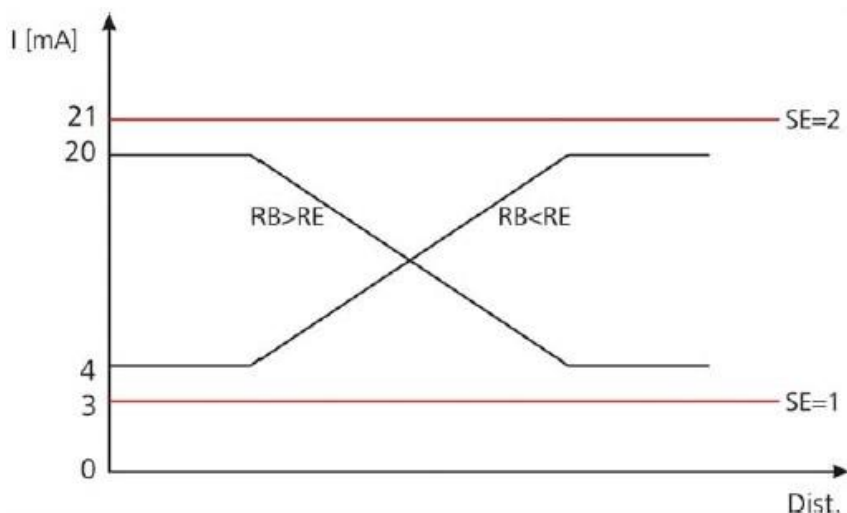

Figure 21 :Output current diagram for RE > RB and RE < RB

To match analog output behavior in the event of an error message (E15, E16, E17, E18), appropriate settings can be made under "SE"(see 8.13, SE – display/set error mode [0/1/2])

9.6 Trigger Input²⁰

The trigger input is intended for triggering a distance measurement with an external signal that is applied as a voltage pulse between 3 V and 24 V. This

²⁰ Trigger function is not available for devices with internal heating (CLDM41A-h and CLDM42A-h)

input is used only in trigger mode DF (DF – distance measurement with external trigger)!

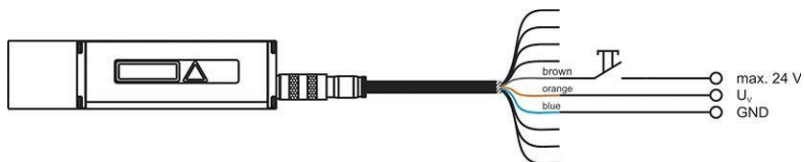

Figure 22 : Wiring diagram of trigger input

It is for the user to specify a desired delay time and a pulse slope to be selected for synchronization (see 8.22, TDx y – display/set trigger delay trigger level). The distance measurement will always be started with a delay of 5 ms in addition with the programmed trigger delay time.

Having done this, the CLDM41A and CLDM42A has to be switched to trigger mode (see 8.6, DF – distance measurement with external trigger).

10 List of Commands

Table 8 : List of commands

Command	Description
DT	Starts distance tracking
DS	Starts distance tracking (< 7 m)
DW	Starts distance tracking on white target at 10 Hz
DX	Starts distance tracking on white target at 50 Hz (only CLDM42A)
DF²¹	Starts remote-triggered single distance measurement (single shot)
DM	Starts single distance measurement (single shot)
TP	Queries inner temperature
SA	Queries / sets floating average value (1...20)
SD	Queries / sets output format (dec/hex/sig)
ST	Queries / sets time to measure (0...25)
SF	Queries / sets scale factor
SE	Queries / sets error mode (0, 1, 2)
AC	Queries / sets alarm center
AH	Queries / sets alarm hysteresis
AW	Queries / sets alarm with
HO²²	Queries / sets temperature for heating on
HF²³	Queries / sets temperature for heating off
RB	Queries / sets beginning of range (4 mA)
RE	Queries / sets end of range (20 mA)
RM	Queries / sets removal measurement parameters
TD	Queries / sets trigger delay and level
TM	Queries / sets trigger mode and level
BR	Queries / sets baud rate

²¹ Trigger function is not available for devices with internal heating (CLDM41A-h and CLDM42A-h)

²² Only for devices with internal heating (CLDM41A-h and CLDM42A-h)

AS	Queries / sets auto start
-----------	---------------------------

List of Commands

Command	Description
OF	Queries / sets offset
SO	Sets current distance as offset
LO	Turns Laser on (do not use, please use DT)
LF	Turns Laser off
PA	Displays all parameter values
PR	Resets all parameters to standard values (don't use)

11 Error Codes

Table 9 : Error Codes

Code	Description	Action
E15	Reflexes are too weak, or distance from LDM (front edge) to target is less than 0.1 m	Use white target board ²³ or increase distance to target
E16	Reflexes are too strong	Use white target board or filter
E17	Too much steady light (e.g. sun) or reflexes are too strong	Use aperture or filter or white target board
E18	DX mode (only CLDM42A): reflexes too weak, or distance from LDM (front edge) to target is less than 0.1 m	Use white target board or increase distance to target
E19	DX mode (only CLDM42A): Target motion speed > 10 m/s	Reduce motion speed
E23	Inner temperature below – 10°C	Heating necessary
E24	Inner temperature above + 60°C	Cooling necessary
E31	EEPROM checksum error	Necessary to repair
E51	Failed to set avalanche voltage	Necessary to repair
E52	Excessively high Laser current / Laser defect	Necessary to repair
E53	Division by 0	SF must be unequal of zero or necessary to repair
E54	Hardware error, PLL range	Necessary to repair
E55	Other hardware error	Necessary to repair
E61	Invalid command	Correct input
E62	Wrong parameter, wrong command	Check data transmission
E63	SIO overflow	Check data transmission
E64	SIO framing error	Check data transmission

²³ e.g. 3M, self adhesive foil matte white

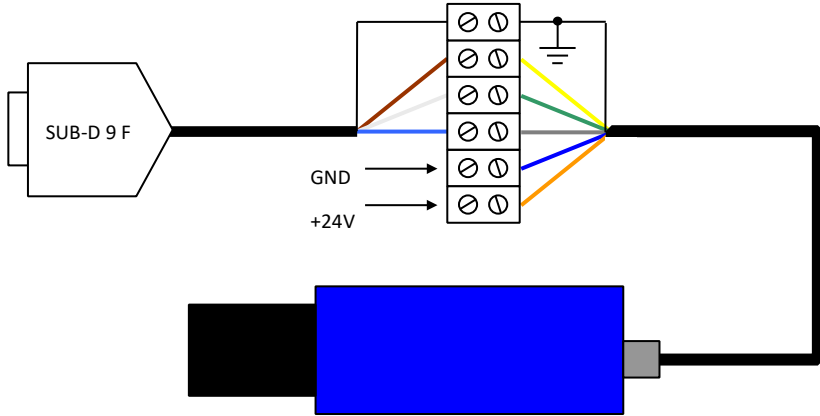
PC Interface Cable (Option)**Figure 23 : RS232 cable with power supply for CLDM41A and CLDM42A****Table 10 : Pin assignment SUB-D 9 F**

Nr.	SUB-D 9 F	Color code	Designation SUB-D 9 F (PC COM)
	Shield	-	Cable shield
3		brown	TxD
2		white	RxD
5		blue	GND

Table 11 : Pin assignment CLDM41A and CLDM42A

Pin	and CLDM4 1A LDM-42A	Color code	Designation CLDM41A and CLDM42A / RS232
	Shield	-	Cable shield
A		green	TxD / RX+
B		yellow	RxD / RX-
C ²⁴		brown	TRIG
D		red	IOUT
E		black	TX-

²⁴ Trigger function is not available for devices with internal heating (CLDM41A-h and CLDM42A-h)

F	purple	TX+
G	orange	VCC
H	white	ALARM
J	grey	GND
L	blue	GND

RS232 Kabel: TXD and RXD are necessary to cross

12 EG Declaration of Conformity

In accordance with the

Directive of Electromagnetic Compatibility 2004/108/EG

The company ASTECH Angewandte Sensortechnik GmbH in Schonenfahrerstr. 5, 18057 Rostock / Germany herewith declare, represented by the signatory, that the following designated product

Laser Distance Measurement Sensor

CLDM41A / CLDM42A

agree with the following harmonized standard:

IEC 61326-1

Electromagnetic interference and electromagnetic compatibility (EMC)

***including radio interference**

Rostock, 21. September 2010

ASTECH Angewandte Sensortechnik GmbH

14 Part Numbers

Table 12 : Part Numbers

Name

CLDM41A

CLDM41A-RS232

CLDM42A

CLDM42A-RS232

CLDM41A-h with heating

CLDM41A-RS232-h with heating

CLDM42A/h with heating

CLDM42A-RS232-h with heating

CLDM41A with pressure equalizing element

CLDM41A-RS232 with pressure equalizing element

Protection window Standard for CLDM4x-Serie

Protection window Quartz glass for CLDM4x-Serie

Protection window Sapphire glass for CLDM4x-Serie

Gray filter 2-fach for CLDM4x-Serie

Gray filter 4-fach for CLDM4x-Serie

Reflection foil matte/white, A4

Highly reflective foil silver, A4

Protection tube for pressure air for CLDM4x-Serie

Interface cable 30 meters length

Fixing device BR type with bolts

RS232-Kabel D-SUB9F/luster clamp, 2m for LDM-Series

ASTECH USB Stick (Documentation and Software)

Printed Manual CLDM41A and CLDM42A, A5, DE

Printed Manual CLDM41A and CLDM42A, A5, EN

License number for PC-Software LDMT00L for LDM3x und CLDM4x

Note: Several single sensors are also available as packages including sensor and cable, manual and CD (sets). Additionally are other protection enclosures

Fos additional info / special requests please contact our exclusive distributor in Brazil: CAPI Control e Automação Ltda (19) 3604.7068 / 3468.1791